



Palstar Incorporated
9676 N. Looney Rd.,
Piqua, OH 45356 USA
Customer Service and Sales Telephone:
1-800-773-7931
Fax:
1-937-773-8003
Email:
info@palstar.com

AT-500 600W PEP Antenna Tuner

*160 Meter to 6 Meter
Peak/Peak Hold Metering
Differential-T Antenna Tuner*

Owner's Manual



© Copyright 2008 Palstar Inc.
Printed in the U.S.A.

WARNING: TO PREVENT FIRE OR ELECTRICAL SHOCK DO NOT EXPOSE TO RAIN OR MOISTURE

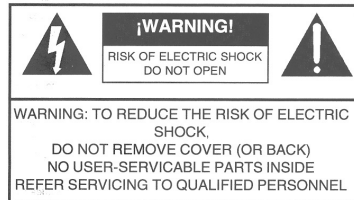

The lightning flash with arrow head symbol, within an equilateral triangle, is intended to alert the user to the presence of uninsulated "dangerous voltage" within the product's enclosure that may be of sufficient magnitude to constitute a risk of electric shock to persons.



The exclamation point within an equilateral triangle is intended to alert the user to the presence of important operating and maintenance (servicing) instructions in the literature accompanying the appliance.

WARNING: TO REDUCE THE RISK OF FIRE OR ELECTRIC SHOCK, DO NOT EXPOSE THIS APPLIANCE TO RAIN OR MOISTURE. DO NOT OPEN THE CABINET WHILE OPERATING. REFER SERVICING TO QUALIFIED PERSONNEL ONLY.

CAUTION: TO PREVENT ELECTRIC SHOCK, DO NOT USE THE THREE WIRE CORD WITH AN EXTENSION CORD RECEPTACLE OR OTHER OUTLET UNLESS THE BLADES CAN BE FULLY INSERTED TO PREVENT BLADE EXPOSURE.

1. Read Instructions—All the safety and operating instructions should be read before the appliance is operated.

2. Retain Instructions—The safety and operating instructions should be retained for future reference.

3. Heed Warnings—All warnings on the appliance should be adhered to.

4. Follow Instructions—All operating and use instructions should be followed.

5. Cleaning—Unplug this appliance from the wall outlet before cleaning. Do not use liquid cleaners or aerosol cleaners. Use a damp cloth for cleaning.

6. Do Not Use Attachments—not recommended by the manufacturer or they may cause hazards.

7. Water and Moisture—Do not use this product near water—for example, near a bathtub, wash bowl, kitchen sink, laundry tub, in a wet basement, or near a swimming pool—and the like.

8. Accessories—Do not place this product on an unstable cart, stand, tripod, bracket, or table. The product may fall, causing serious injury to a child or adult, and serious damage to the appliance.

9. Ventilation—This product should never be placed near or over a radiator or heat register. This product should not be placed in a built-in installation such as a bookcase or rack unless

proper ventilation is provided or the manufacturer's instructions have been adhered to. Any slots or openings in the cabinet are provided for ventilation. To ensure reliable operation and to protect it from overheating, these openings must not be blocked or covered. The openings should never be blocked by placing the product on a bed, sofa, rug, or other similar surface.

10. Power Sources—This product should be operated only from the type of power source indicated in the owner's manual.

11. Power-cord Protection—Power-supply cords should be routed so they are not likely to be walked on or pinched by items placed upon or against them. Pay particular attention to cords at plugs, convenience receptacles, and the point where they exit.

12. Lightning—For added protection for this product during a lightning storm, or when it is left unattended and unused for long periods of time, unplug it from the wall outlet.

13. Power Lines—An outside antenna system should not be located in the vicinity of overhead power lines, other electric light or power circuits, where it can fall into such power lines or circuits. When installing an outside antenna system, extreme care should be taken to keep from touching such power lines or circuits as contact with them may be fatal.

Limited Warranty

Palstar Inc. warrants products manufactured by it to be free from defects in material and workmanship under normal use and service for a period of one (1) year from the date of delivery to the first buyer (the "Warranty Period"). Palstar Inc's obligation under this warranty is limited to repair or replacement of the product; at its option at the Palstar factory in Piqua, OH.

Effective only when the product is returned to the factory with all transportation charges prepaid and examination of the product discloses in Palstar's judgment, to have been defective during the Warranty Period.

The Warranty Period shall not extend beyond its original term with respect to interim in-warranty repairs by Palstar. This Warranty Period shall not apply to any product which has been repaired or altered by anyone other than Palstar without prior written authorization. Warranty does not extend to any products which have been subject to damage from improper installation, application or maintenance in accordance with the operating specification. Palstar neither assumes nor authorizes any person to assume for it any obligation or liability other than herein stated.

Repair Policy

When sending in a product for service, please "double" box it carefully and ship it insured for your protection. Please include a note clearly describing the problem, how you wish the item returned and how you wish to pay for

the service. Package your unit properly. Palstar, Inc. is not responsible for merchandise damaged in shipment. Our service rate is \$30 per hour (1/2 hr. minimum).

Return Policy

All returns must receive prior authorization from Palstar. Returned items must be received in original—AS SHIPPED—condition including the original box, manuals, accessories, and copy of sales receipt. Returns must be within 14 days of purchase. Returned items are subject to a 25% restocking fee. Shipping is not refundable.

14. Overloading—Do not overload wall outlets and extension cords as this can result in a risk of fire or electric shock.

15. Object and Liquid Entry—Never push objects of any kind into this product through openings as they may touch dangerous voltage points or short-out parts that could result in a fire or electric shock. Never spill liquid of any kind on the product.

16. Servicing—Do not attempt to service this product yourself as opening or removing covers may expose you to dangerous voltage or other hazards. Refer all servicing to qualified service personnel.

17. Damage Requiring Service—Unplug this product from the wall outlet and refer servicing to qualified service personnel under the following conditions:

- When the power-supply cord or plug is damaged.
- If liquid has been spilled, or objects have fallen into the product.
- If the product has been exposed to rain or water.
- If the product does not operate normally by following the operating instructions. Adjust only those controls that are covered by the operating instructions. An improper adjustment may result in damage and will often require extensive work by a qualified technician to restore the product to its normal operation.
- If the product has been dropped or the cabinet has been damaged.
- When the product exhibits a distinct change in performance—this indicates a need for service.

18. Replacement Parts—when replacement parts are required, be sure the service technician has used replacement parts specified by the manufacturer or have the same characteristics as the original parts. Unauthorized substitutes may result in fire, electric shock or other hazards.

19. Safety Checks—Upon completion of any service or repairs to this product, ask the service technician to perform safety checks to determine that the product is in proper operating condition.

20. Outdoor Antenna Grounding—Before attempting to install this product, be sure the antenna or cable system is grounded so as to provide some protection against voltage surges and built-up static charges.

- Use No.10 AWG copper, No.8AWG aluminum, No.17AWB copper-clad steel or bronze wire or larger, as ground wire.
- Secure antenna lead-in and ground wires to house with stand-off insulators spaced from 4 feet to 6 feet apart.
- Mount antenna discharge unit as close as possible to where lead-in enters house.
- A driven rod may be used as the grounding electrode where other types of electrode systems do not exist. Refer to the National Electric Code, ANSI/NFPA 70-1990 for information.
- Use jumper wire not smaller than No.6 AWG copper or equivalent, when a separate antenna grounding electrode is used.

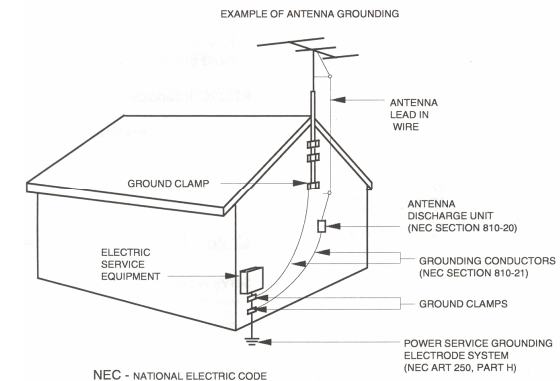

4 Table of Contents

Thank you for purchasing a Palstar AT-500 Antenna Tuner. This antenna tuner has been designed and manufactured to high quality standards, and will provide reliable operation for many years.

Please carefully read the Owner's Manual in order to take advantage of the many features that will provide years of enjoyable amateur radio operation.

Important safeguards	2
Table of Contents	4
General Description	5
Installation	6
Unpacking	6
Location	6
Installation Procedures	6
Rear Panel Connections	7
Front Panel Description	8
AT-500 Schematic	10
Operating Your AT-500	12
Before Operating	12
Tuning	12
Notes	14
Specifications	15
Meter Board Adjustments	16
Inside View	17
Service and Warranty	19

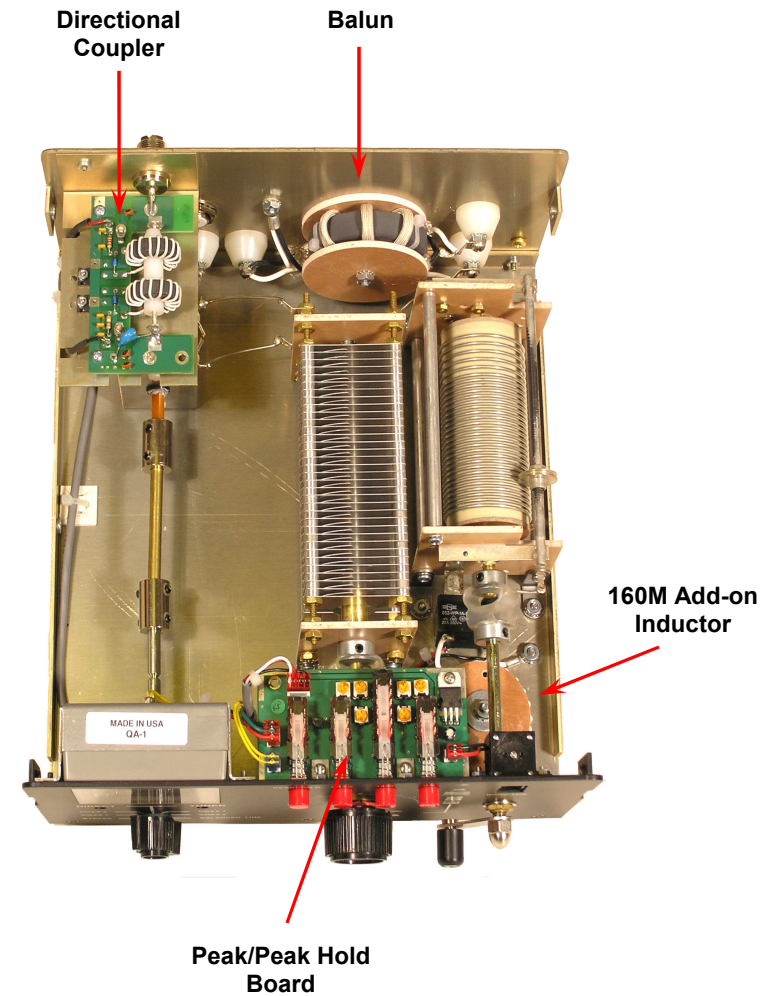

16 Meter Board Adjustments

Note: These adjustments control the calibration and accuracy of the AT-500's metering. Do not adjust unless you are sure the metering is inaccurate, and you have accurate test equipment to check against.

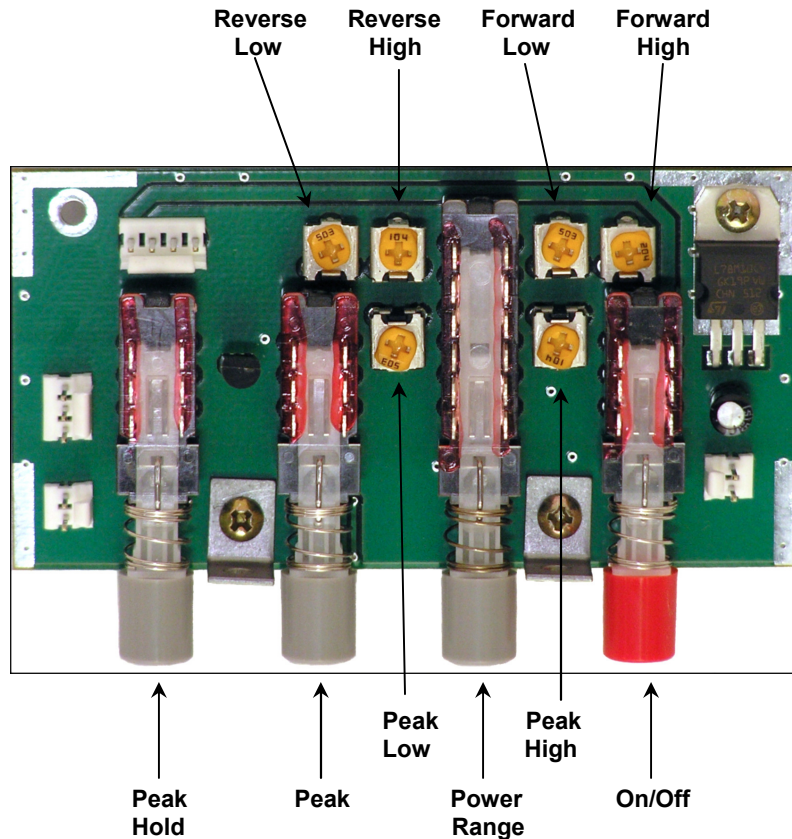

Note: The adjustment pots on your meter board may differ in appearance from the photograph.

General Description 5



The Palstar AT-500 Antenna Tuner is an American made impedance matching network. The AT-500 is designed to handle both Balanced line feeds and Coax feeds.

The AT-500 optimizes the performance of your antenna and transmitter or SWL receiver by providing adjustable impedance matching using a T-type circuit configuration with a dual-stator differential variable capacitor.

The AT-500 also measures the power and Voltage Standing Wave Ratio (VSWR or SWR) which allows you to tune the SWR to the lowest ratio possible for the selected transmission frequency.

The AT-500 features a precision roller inductor with a steatite ceramic core. The innovative differential capacitor design simplifies operation by reducing the number of knobs and eliminating false peaks while tuning. It also results in a more compact case that takes up less room on the operating desk.

Tuning is achieved with the front panel mounted controls. The Vernier dial allows for fine tuning with precision and accuracy, while the Inductor crank handle facilitates coarse adjustments.

Unpacking

Carefully remove the AT-500 from the shipping carton and inspect it for signs of damage. If any damage is apparent, notify the transportation carrier or dealer immediately. **We recommend keeping the packing carton for moving, storing or reshipping the tuner to us for repair if required.**

Location

Select a location for the AT-500 that allows the connectors to be free from any possible contact with people, pets or objects during operation and with unrestricted air flow for cooling.

panel. These connectors are either direct from the transmitter or through the tuned circuit depending on the setting of the DIRECT/TUNED mode switch on the front panel.

For a balanced feed antenna connect a balanced feed line to the upper and lower BALANCED OUTPUT posts, and the supplied jumper strap between the END FED WIRE post and the post provided for the jumper (see pg. 10).

If using a single wire antenna, connect it to the END FED WIRE post and remove the



WARNING: Balanced antennas will produce high RF voltages at the output post connectors. RF burns may result if touched during transmission.

Installation Procedures

Connect a coax cable from your transmitter to the RF INPUT connector on the rear panel.

Keep the cable as short as possible. If you use a linear amplifier, connect your transmitter to the linear amplifier input and the linear amplifier output to the AT-500. **Do not use more than 800 Watts average (single tone) through the tuner.**

Connect coax cable(s) from your antenna to COAX 1 or COAX 2 connectors on the rear

jumper strap. When using an END FED WIRE antenna the GROUND post must be connected to a good RF ground.

Connect a dummy load to the BYPASS connector using a coax cable. This lets you select the dummy load from the DIRECT/TUNED mode switch. Any antenna that does not require the use of an antenna tuner may be connected to the BYPASS connector, if desired.

Front Panel Indicators and Controls

Metering	Dual movement cross needle power and frequency compensated coupler
Controls	
Input Tuning	Dual-stator differential capacitor (360 - 14 - 360) pF, 2.5 kV) with 6:1 precision vernier drive
Inductance	15 μ H roller inductor; 14 ga. wire wound on steatite ceramic core, silver plated bar/wheel. A 12 μ H fixed toroid add-on inductance for 160 M, wound with 14 ga. Teflon wire, is switched in and out of circuit by front panel switch-controlled relay
Antenna Selector Switch	6 position: Coax 1 tuned and tuner bypass Coax 2 tuned and tuner bypass Bypass and balanced antenna
Power Range Switch	2 position 300 W /1000 W

Rear Panel Connectors

Coax 1	SO239 connector
Coax 2	SO239 connector
Bypass	SO239 connector
RF INPUT	SO239 connector
Balanced Line	Dual High Voltage Nylon66™ terminal post
End -Fed Wire	High Voltage Nylon66™ terminal post
12 VDC Input	14mm connector (2.1mm ID, 5.5mm OD, center positive, 200ma)

Other

Frequency Coverage	1.8 — 54 MHz
Power Maximum	600 Watts PEP SSB; 500 Watts CW
Impedance Range	20 to 1500 Ω 160 m to 6 m (assuming resistive load) Reduce power for lower Z range
Balanced Output	4:1 current balun
Dimensions	5.5"H x 10"W x 11.3"D (incl. terminals)
Weight	8 lbs.
Materials	Chassis and top cover is 11 ga. (.090) aluminum that has been chem-film treated. Front panel and top cover are powder coated

needles intersect. Repeat adjusting the Tune and Inductor controls until the lowest SWR reading is obtained. This procedure takes patience the first time. The Tune control varies the capacitor and provides fine adjustments. The roller inductor crank control provides coarse adjustment.

10. When you have tuned your antenna to the best SWR, record the settings of the TUNE and INDUCTANCE controls on the chart on page 12 for future reference. When you re-tune, use these settings as your starting point.

Notes:

1. An SWR of 1:1 is best, but an SWR as high as 2:1 may be acceptable. Check your transmitter/amplifier manual for details.
2. If you cannot get an acceptable SWR, lengthen or shorten your antenna and/or feedlines and retune.
3. Any time a new or different antenna is connected, it is necessary to repeat the tuning procedure for each antenna.
4. Once every 4-6 months clean the roller coil with 70% isopropyl alcohol and a clean cotton cloth. **Do not remove the conducting grease on the rod that guides the roller wheel. Do not transfer any of the conducting grease from the rod to the roller coil body, as this will contaminate the windings.**

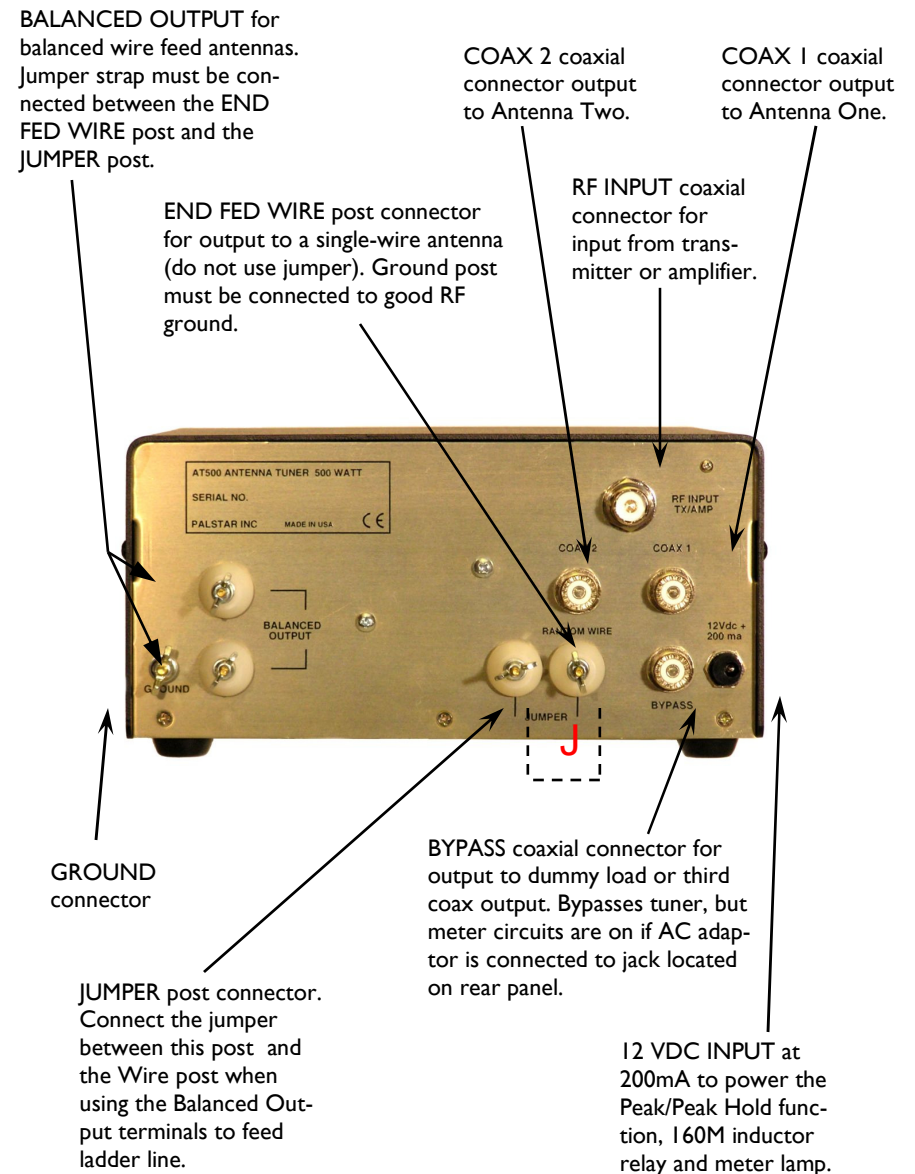
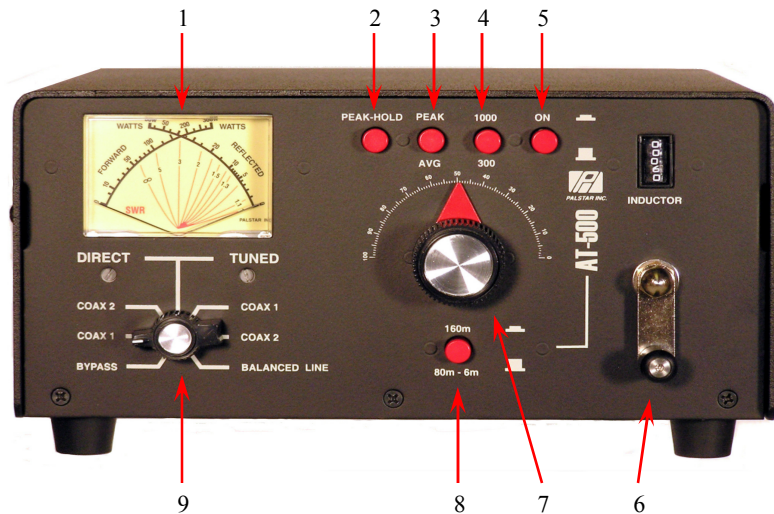

FIGURE 1: REAR PANEL CONNECTORS

8 Front Panel Description



- 1. POWER/SWR METER** Dual needle meter displays FORWARD and REFLECTED power in Watts. SWR is measured where the two needles intersect on the red scale.
- 2. PEAK HOLD** Select to read Peak Hold on the SWR meter.
- 3. PEAK** Selects between PEAK and AVERAGE Power metering display.
- 4. RANGE** Two-position switch selects the range of FORWARD and REFLECTED power displayed on the power meter. When the RANGE button is OUT, the FORWARD meter scale reads 300 Watts full scale and the REFLECTED meter scale reads 60 Watts full scale. When the RANGE button is IN, the FORWARD meter scale reads 3000 Watts full scale and the REFLECTED meter scale reads 600 Watts full scale.
- 5. POWER** Select to turn on the backlight in the meter and enable Peak, Peak Hold, and 160 Meter functions. The jack on the back panel must be supplied with 12 VDC for this to function.

1-800-773-7931 WWW.PALSTAR.COM

Operating Your AT-500 cont'd 13

1. Select the band and frequency of desired operation.
2. Set TUNE and INDUCTOR controls to the suggested setting before applying transmitter power (see chart). Actual settings will vary from antenna to antenna.
3. Set your transmitter/amp to a low power output. If your transmitter has a TUNE position, select that position.
4. If you use a linear amplifier, set it to Standby. Do not use the linear amplifier until the AT-500 is tuned. Do not exceed 500 Watts average (single tone) during tune-up.
5. Set RANGE switch to 300 W (button out).
6. Set the DIRECT/TUNED mode switch to the position matching your antenna connection. To tune your antenna, the switch selection must be set to: COAX 1 TUNED, COAX 2 TUNED or WIRE (BALANCED ANTENNA). Selecting COAX 1 DIRECT, COAX 2 DIRECT or BYPASS bypasses the tuning selection.

CAUTION: When approaching the end stops of the roller inductor, (readings of zero or 288) SLOW DOWN. Slamming the roller wheel into the mechanical end stops on either end of the roller inductor can damage it.

7. Rotate the TUNE and INDUCTOR controls for maximum noise or signal as heard on your receiver. Refer to preset tuning chart on page 12.
8. Key your transmitter and adjust the power level for a reading of 100-150 Watts on the FORWARD scale. Adjust the TUNE and INDUCTOR controls for a minimum REFLECTED reading while maintaining a FORWARD reading of 50-100 Watts using your transmitter power control.
9. Read the SWR on the red scale at the point where the two

1-800-773-7931 WWW.PALSTAR.COM



WARNING: DO NOT OPERATE THE AT-500 WITH THE COVER OFF.

Before Operating

1. To avoid possible damage to the AT-500 set the POWER RANGE switch to the OUT position (Low range) and set the TUNE and INDUCTOR as outlined in the chart before applying transmitter power.

2. Begin tuning with your transmitter/amp into the tuner set at a low output power setting (50-100 Watts).

Tuning

Note: The AT-500 must be supplied with 12VDC to operate the relay in order to use it on any band other than 160 Meters, and for the metering to work.

BAND	TUNE		INDUCTOR	
	SUGGESTED	ACTUAL	SUGGESTED	ACTUAL
160 M	52		68	
80 M	52		160	
60 M	52		214	
40 M	52		240	
30 M	50		263	
20 M	52		277	
17 M	52		284	
15 M	50		286	
12 M	50		282	
10 M	52		280	
6M	85		281	

6. INDUCTOR 15 μ H continuously variable ceramic roller inductor driven by a crank handle with gear-driven precision mechanical counter. A reading of Zero is maximum inductance, A reading of 288 is minimum inductance.

7. TUNE Continuously adjustable differential capacitor.

8. 160 METER SWITCH Pushing this button to the IN position switches in extra inductance for the 160 Meter Band. The button should be in the OUT position for use on all other bands — 80 through 6 Meters. (Requires 12VDC power.)

9. DIRECT/TUNED MODE SWITCH Six-position rotary switch selects an output coaxial connector with direct mode which bypasses the tuner and tuned position which passes antenna through the tuner components.

a. DIRECT BYPASS selects BYPASS COAX connector, bypassing the impedance matching circuit but providing SWR, FORWARD and REFLECTED meter readings.

b. DIRECT COAX 1 selects COAX 1 connector, bypassing the tuner matching circuit but providing SWR, FORWARD and REFLECTED meter readings.

c. DIRECT COAX 2 selects COAX 2 connector, bypassing the tuner matching circuit but providing SWR, FORWARD and REFLECTED meter readings.

d. TUNED COAX 1 selects COAX 1 connector through the impedance matching T circuit.

e. TUNED COAX 2 selects COAX 2 connector through the tuner matching T circuit.

f. BALANCED OUT selects the balanced and End Fed Wire output connectors located after the impedance matching circuit.

Schematic Diagram

AT-500 Antenna Tuner

